

 **Minimax**

**GILPRO**

# PRODUCT PORTFOLIO

Fire products and  
solutions from your  
caring partner  
in fire safety



A **GUNNEBO**® BRAND

## Fire Extinguishers

Minimax Fire Extinguishers, in India since 1903, is the most trusted and reliable fire extinguisher in the Indian market. Reputed for maintaining the highest Quality standards, Minimax fire products are manufactured by Gunnebo India a subsidiary of the Gunnebo Group, Sweden. The manufacturing unit in Halol carries the ISO9001 Quality Certification, ISO 14001 Environmental Certification, and ISO 45001 certification on Occupational Health and Safety.

The fire extinguisher range includes a combination of Portable, Mobile & Ceiling mounted types with various capacities and agents suitable for A, B, C, D, F, and electrically induced fires.

Approvals: **BIS, EN, CE, IRS**



Category	Types of Extinguishers	Classes of Fire	Agent	Capacities
<b>Stored Pressure</b> Portable	ABC Powder	A, B, C & ⚡	MAP Powder (MAP 50 or MAP 90)	1, 2, 4, 6, 9 kg
	BC Powder	B, C & ⚡	SBC Powder	1, 2, 4, 6, 9 kg
	Water	A	Water + Additive	2, 6, 9 ltr
	Water Mist	A	Water + AFFF Base	9 ltr
	Foam	A & B	Water + AFFF / AR-AFFF	2, 4, 6, 9 ltr
	Clean Agent	A, B, C & ⚡	Grenoz®	0.5, 1, 2, 4, 6, 9 kg
	Carbon Di-oxide	B, C & ⚡	CO2 Gas	2, 3, 4.5 kg
	F-Class	A & F	Wet Chemical	2, 4, 6, 9 ltr
D-Class	D	TEC Powder	10 kg	
<b>Gas Cartridge</b> Portable	ABC Powder	A, B, C & ⚡	MAP Powder (MAP 50 or MAP 90)	4, 6, 9 kg
	BC Powder	B, C & ⚡	SBC Powder	4, 6, 9 kg
	Water	A	Water + Additive	6, 9 ltr
	Foam	A & B	Water + AFFF / AR-AFFF	6, 9 ltr
<b>Trolley Mounted</b> Mobile	ABC Powder	A, B, C & ⚡	MAP Powder (MAP 50 or MAP 90)	25, 50, 75 kg
	BC Powder	B, C & ⚡	SBC Powder	25, 50, 75 kg
	Water	A	Water + Additive	20, 60 ltr
	Mechanical Foam	A & B	Water + AFFF / AR-AFFF	20, 60, 150 ltr
	Carbon Di-oxide	B, C & ⚡	CO2 Gas	6.5, 9, 22.5, 45 kg
<b>Modular Type</b> Ceiling Mounted	ABC Powder	A, B, C & ⚡	MAP Powder (MAP 50 or MAP 90)	5, 10 kg
	Clean Agent	A, B, C & ⚡	Grenoz®	5, 6, 10, 12 kg



## FIRESPOT® Automatic Fire Suppression Systems

An unprecedented fire by most common sources like loose connections, overloaded circuits, equipment failure, fatigued electrical wiring, improper installations etc. in unmanned rooms, enclosed panels, high risk machines and vital equipment can cause heavy downtime and huge commercial impacts. Minimax FIRESPOT® automatic fire suppression system controls and extinguishes fire without human intervention in the early stages and is designed for specific applications.

### FIRESPOT® Panel Protection System

FIRESPOT® Panel Protection System is available in 2, 3, 4 & 6 kg cylinder capacities with UL Listed Grenoz® Clean Agent. System accessories include components such as UL Listed Polyamide Tube, UL Listed Hooter, Monitoring Panel, etc.

This pre-engineered system is activated by a pressurized heat sensing tube which ruptures at the spot where fire occurs and suppresses the fire at its origin.

FIRESPOT® Panel Protection System is the most effective and reliable product for protection of enclosed panels or cabinets from fire. The system is approved by National Test House, Central Govt. testing Laboratory of India.

Ideal applications for system installation are Main LT Panel, HT Panel, MCC and Switchgear Panels, Engine compartments of vehicles, Computer Server racks, UPS and Battery Enclosures, HUB and Router Cabinets, Underground cable tracks, overhead trays, Relay panels etc.



### FIRESPOT® Room Protection System

FIRESPOT® Room Protection System is available in 10 & 12 kg ceiling mounted cylinders with UL Listed Grenoz® Clean Agent. System accessories include components such as Gas Release Panel, Multisensor Detectors, Manual Release Switch, UL Listed Hooter, etc.

In case of fire, the detector sends signal to the fire alarm panel, which triggers the electrical actuator on the cylinder valve to discharge the agent into the room thereby suppressing the fire.

FIRESPOT® Room Protection System is the most effective and reliable product for protection of small rooms or cabins. The system is approved by National Test House, Central Govt. testing Laboratory of India.

This system is best suited for electrical panel rooms, UPS and battery rooms, switchboard, record, and server rooms etc.

## instaproteKt - Kitchen Hood Fire Suppression System

GILPRO instaproteKt Kitchen Hood Fire Suppression is an ideal solution specifically designed to protect areas associated with kitchen ventilation equipment including hoods, ducts, plenums, and filters installed in industrial and commercial kitchens.

The instaproteKt system comes with highly proven advanced technology with GSMART PLC control panel and stainless-steel probe type heat detectors. The GSMART PLC based system provides users the control to monitor multiple hoods and can provide event reports and logs for individual hood separately.

The instaproteKt – Optima Series provides an ideal solution specifically for compact hoods. The Optima series model design comes with an agent release panel and Linear Heat Sensing cable. The system is capable of automatic detection and actuation as well as remote manual actuation.



### System Components

- Option 1 - Pre-engineered system with GSMART Advanced PLC Panel with stainless-steel probe type heat detectors
- Option 2 - Pre-engineered system with Agent Release Panel with Linear Heat Sensing Cable
- Stainless Steel (SS304L) Cylinders
- SS 316 Piping, Fittings and Cylinder Enclosure
- High pressure double compression ferrule fittings

### Features

- Activation of solenoid and gas shutoff valve
- Both manual and electrical actuation options
- Discharge of wet chemical through spray nozzles
- Saponification of wet chemical agent negates any reignition
- Integration with BMS or Main FA Panel option available

## CAFS Water Mist Backpack

Water mist is an ideal solution where the environmental concerns continue to increase, and regulations are stringent about the disposal of products that can cause environmental damage.

Compressed Air Foam System uses very fine water sprays in the form of water mist. The small water droplets spread on a more surface area to absorb the heat of the fire, the mist blocks radiant heat transfer to unburned fuel, and it causes local inerting, all while using less water than other water-based systems. The small water droplets allow the water mist to

control, suppress, or extinguish fires by cooling both the flame and surrounding gases by evaporation and displacing oxygen.

Minimax compressed air foam backpack system is an ideal solution for first response in fire trucks & emergency vehicles, industrial, offshore and marine applications.



## Fire Hydrant Modules

Fire Hydrant Modules are the active fire protection measure and a source of connection points that enable firefighters to tap into the water supply to extinguish a fire. Fire hydrant modules are designed to provide quick

responses in saving lives and protecting assets in a fire hazard situation. They are a critical element of fire-safe buildings. Minimax range of fire hydrants is the oldest, most reliable, and holds an extensive installed base in India.



**Valves**

- Single Hydrant Valve
- Double Hydrant Valve
- Collecting Breaching Head (2, 3 & 4 Way)



**Couplings & Nozzles**

- Branch Pipe and Nozzles
- Delivery Hose Coupling
- Draw-off Connection
- Pickup Tubes



**Hose Reel Drum**

- With Rubber or Thermoplastic Hose
- With GM or PVC Nozzle



**Hose Box**

- Double Door MS, SS and FRP



**Fire Hoses**

- Non-Percolating Fire Hose Type 1, 2 & 3
- Control Percolating Fire Hose



**Enclosures**

- Aesthetically designed, Rugged, and Light weight
- For Extinguishers capacities - 6, 9 kg ABC and 4.5 kg CO2.

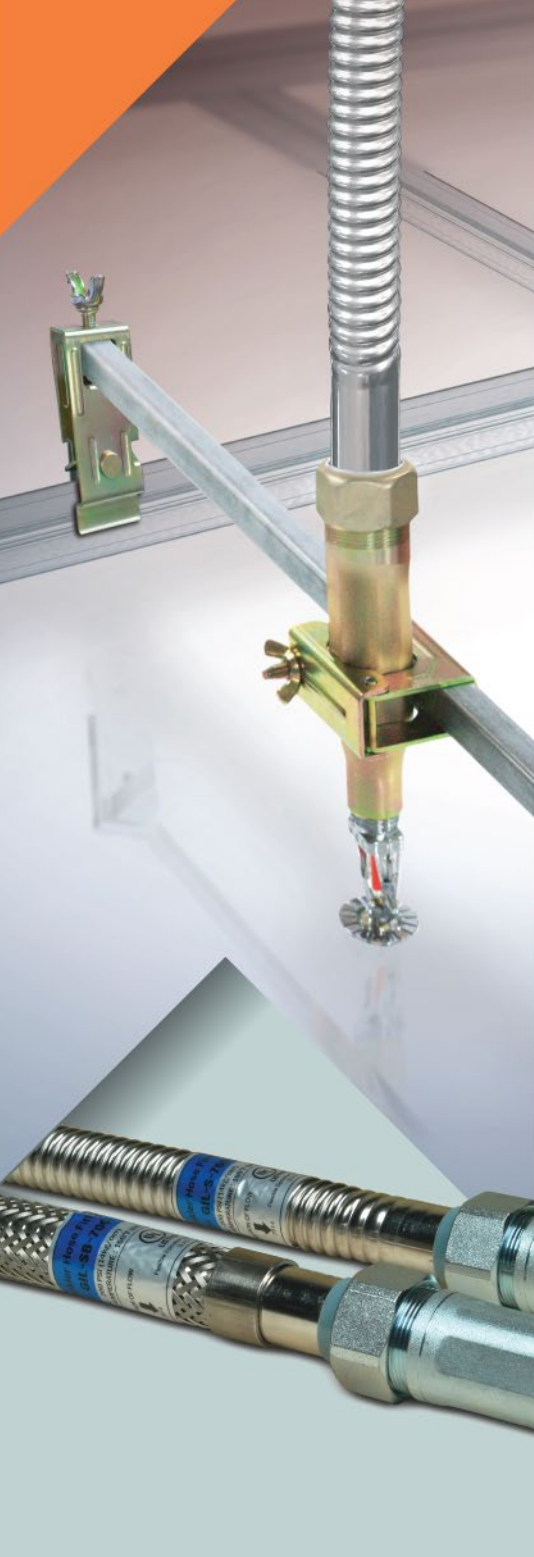

## Flexible Hoses

---

Gunnebo provides highly durable flexible hoses to deliver quality that leads the industry in terms of reliability and performance. GILPRO Flexible Hose with end fittings is an easy-to-install sprinkler drop assembly comprising of 3-piece design with inlet nipple, outlet reducer, and flexible pipe interconnected with slip nuts. The 3-piece design facilitates tightening of inlet adaptor to main pipe without causing any strain on the corrugated pipe section.

---

- Braided (UL Listed & FM Approved) Flexible Hoses
- Unbraided (UL Listed) Flexible Hoses
- Lengths: 700, 1000, 1200, 1500, 1800 mm
- Pressure: 200 psi
- Flexible & quick alternative for rigid piping in difficult locations
- High physical strength combined with light weight
- Resistance to corrosion, fire, moisture, abrasion & penetration
- Absorbs vibration & noise from pumps, compressors, etc.



## The Gunnebo India Manufacturing Facility

GUNNEBO INDIA manufactures the Minimax Fire Extinguishers at its factory in Halol, Gujarat. The company follows the highly efficient GUNNEBO Operating System (GOS) and has a clear focus on quality, delivery, cost, optimum resource usage, health, safety, and secure employee commitment to drive consistent improvement and bring lasting value to customers



PAINTING PROCESS



FIRE TEST



CO<sub>2</sub> FILLING



ASSEMBLY OF FIRE EXTINGUISHERS

A **GUNNEBO**® BRAND

## Gunnebo India Private Limited

**Regd. Office:**

Unit No. 102, 1st floor, Akruti SMC,  
LBS Marg, Khopat, Thane (W) 400 601

**Works:**

1302/1306 GIDC Industrial Estate, Halol, District  
Panchmahals, Gujarat - 389 350

**Email:** [fireproducts.india@gunnebo.com](mailto:fireproducts.india@gunnebo.com)

### Regional Sales Offices

**North:** 1st floor, B-23, Sector 65,  
Noida - 201 307

**East:** 18A Park Street, 3, Stephen Court,  
Block-1, 2nd Floor, Kolkata - 700 071

**South:** OMS Court, 2nd floor, No.1,  
Nathamuni Street, G. N. Chetty Road,  
T. Nagar, Chennai - 600 017

**Customer Care (Toll free):**

**1800 22 3525 | 1800 209 3040**

**+91 22 6780 3600**

**[www.minimax.co.in](http://www.minimax.co.in)**



Scan to visit our website

**Follow us:**

 @MinimaxFireProducts

 @minimax-fire-extinguishers